

EW50 シリーズ

産業用 LTE セルラーゲートウェイ



概要

EW50は重要な建設と産業用環境向けに設計され、7Wで操作できる低い電力消費、公共施設及び様々な過酷な環境に最適な産業用ゲートウェイ製品です。二つイーサネットポートを内蔵し、メンテナンス人員にリアルタイムの遠隔操作を提供し、通信伝送の安定を提供し、遠隔セキュリティーの管理には最適な選択です。

さらに無線、イーサネット、シリアル、デジタルI/Oなど多様な通信経路で様々な環境に対応し、国際LTE通信規格に一致し、遠距離のネットワークの接続にもっと簡単に操作できます。

[Industrial LTE Cellular Gateway | Promotion Page EW50 Series](#)

特長

+ 多種の取付方法を選択可能

イーサネット、デジタル入力/出力、Modbus TCPなど通信プロトコルにサポート。M2MとIIoTに向けるアプリケーション。

+ 高度な接続信頼性

デュアルSIM設計により冗長化技術。フェイルオーバー管理で通信伝送の安定を提供。中断しない4G LTEインターネット接続/IPパススルーモード。

+ 全面的なデータセキュリティ

IPSec、OpenVPN、PPTP、L2TPとVPNにサポートし、同時に16個通信トンネルと接続し、最大70Mbps (IPSec)帯域幅までも可能。

+ 産業用筐体デザイン

IP30、ファンレスで堅牢な筐体。
-30~70°C (-22~158°F)広範囲温度に対応。

仕様

+ Cellular Interface

Standards

- Cellular Frequency Bands: (Please check Frequency Bands Region Codes)
- LTE Cat. 4: FDD-LTE, TDD-LTE, Transfer rate (max):
LTE FDD: 150Mbps down; 50Mbps up
LTE TDD: 130Mbps down; 35Mbps up
- 3G: WCDMA, Transfer rate (max): 42Mbps down; 5.76Mbps up
- 2G: GSM/EDGE, Edge Transfer rate (max): 236.8Kbps down & up

Antenna connector

- 2 x SMA Female

SIM Slot

- 2

+ Ethernet

Standards

- IEEE 802.3 10BASE-T
- IEEE 802.3u 100BASE-TX/100BASE-FX
- IEEE 802.3ab 1000BASE-T

Ports

- 2 x RJ45 GE

Physical Layer

- 10/100/1000BASE-T

+ Serial

Ports

- 2 x RS-232/RS-485

+ I/O

DI/DO

- 1 x Digital In ("Logic 0": 0-2V, "Logic 1": 5V-30V)
- 1 x Digital Out (Relay Mode, up to 30V/1A)

+ USB

Standards

- USB 2.0

Ports

- 1 x USB Type A

+ Micro SD

Capacity

- Max. Storage of 64GB

+ Functions

VLAN

- Port-based, Tag-based VLAN

Port Forwarding

- Virtual Server/Computer (1-1), DMZ Host, PPTP/L2TP/IPSec Pass-through

Routing

- Static, Dynamic: RIP1/RIP2, OSPF, BGP

VPN

- IPSec, OpenVPN, PPTP, L2TP, GRE

Firewall

- SPI Firewall with Stealth Mode, IPS

Event Engine/Event Handling

- Managing/Notifying Events: DI, DO, Modbus, SMS, Syslog, SNMP Trap, Email Alert, Reboot

+ Cloud Development Platform

- Support Microsoft Azure

+ Field Communication

Virtual COM

- RFC2217, TCP Client, TCP Server, UDP

Modbus

- Gateway for Modbus TCP, Modbus RTU/ASCII Master/Slave Access
- Slave for Device Status/Information Access

Data Logging

- Sniffer, Off-line/Full-time Proxy, Mixed modes

Data Interchange

- MQTT Broker, MQTT Client

+ Power

Input

- DC 9V-36V

Power consumption

- 7.0W Max.

+ Mechanical

Dimension

- 31 x 99 x 130.6mm (w/o mounting brackets)

Weight

- 0.9Kg (1.98lb)

Installation

- DIN-Rail

+ Environment

Operating Temperature

- -30 to 70°C (-22 to 158°F)

Storage Temperature

- -40 to 85°C (-40 to 185°F)

Ambient Relative Humidity

- 5% to 95%

+ Regulatory Approvals

Safety

- EN 60950-1
- EN 62368-1: 2014

Emissions/Immunity

EW50-TA FCC/NCC/RCM

EW50-EUS FCC/CE/NBTC/NTC/KC*/SDPPI**

EW50-JP VCCI/JATE

Note:

KC*: EW50 doesn't support SKT SIM card,
suggest to use Global SIM card or Non-SKT
SIM Card.

SDPPI**: Indonesia Radio Type Approval

78410/SDPPI/2021

13696

応用例

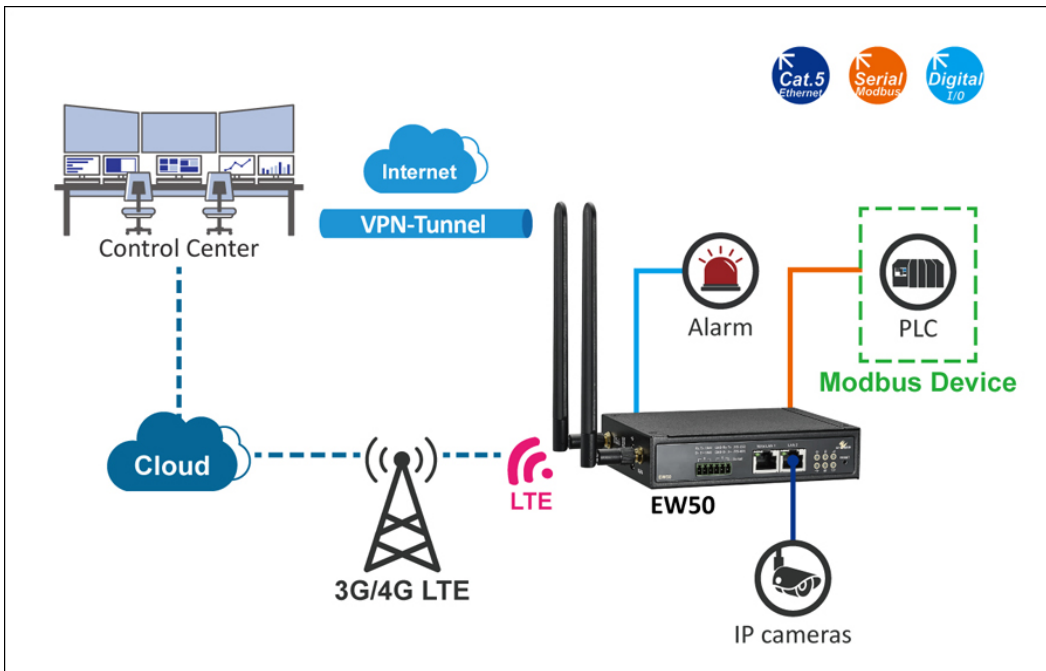

寸法図

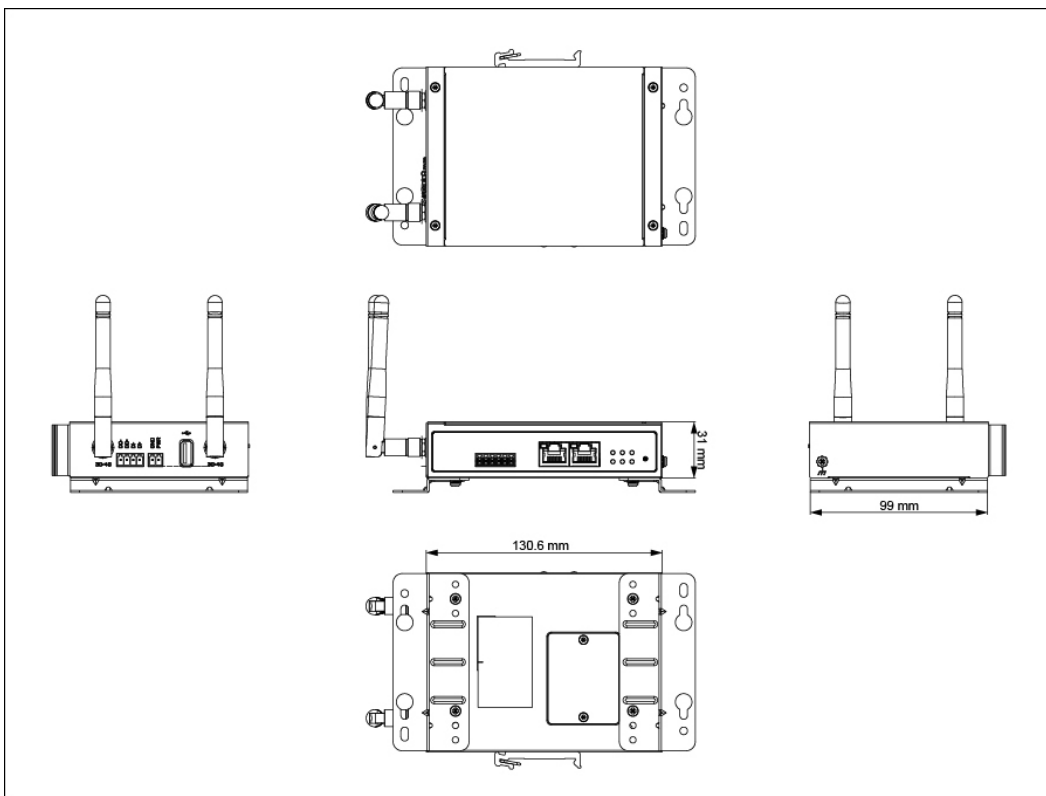

周波数帯域



Sku Code	4G LTE		3G	2G	Region
	FDD LTE	TDD LTE	WCDMA	GSM/EDGE	
TA	B1(2100)/ 3(1800)/ 4(AWS)/ 5(850)/ 7(2600)/ 8(900)/ 28(700 APT)	B40(2300)	B1(2100)/ 2(1900)/ 5(850)/ 8(900)	B2(1900)/ 3(1800)/ 5(850)/ 8(900)	Taiwan, Australia
EUS	B1(2100) / 3(1800) / 5(850) /7(2600) / 8(900) / 20(800)	B38(TD 2600)/ 40(TDV 2300)/ 41(TD 2500)	B1/ B5/ B8	B3(1800)/ 8(900)	EU, Singapore, Malaysia, Vietnam, Thailand, Turkey, Philippines, India, Indonesia, South Korea
JP	B1(2100)/ B3(1800)/ B8(900)/ B18(800 Lower)/ B19(800 Upper)/ B26	B41(TD 2500)	B1(2100)/ 6(UMTS only)/ 8(900)/ 19(800 Upper)	-	Japan

製品型番

型番

EW50-EUS	Industrial LTE Cellular Gateway-EUROPE & SOUTH ASIA
EW50-TA	Industrial LTE Cellular Gateway-TAIWAN & AUSTRALIA
EW50-JP	Industrial LTE Cellular Gateway-JAPAN

Optional Accessories

GWAP-1		Item	Amount	Frequency	Description	Note
	LTE	2	698-960/ 1710-2170/ 2300-2690MHz	Cellular Omni Antenna, N/female Jack Bulkhead	IP67	
	Surge Protector	2	-	0-6GHz Surge Lightning Protector, N/female Jack Bulkhead To N/male Plug	IP67	
	Bracket	2	-	-	-	
	LTE Cable	2	-	SMA/male Plug To N/male Plug with NFC200 Cable	-	
P/N.	Image	Item	Amount	Frequency	Description	Note
W96G-11361Y50S	 <small>Image not found or not available</small>	Wall Mount Kit	1 set	-	1 set package includes 2 wall mount (Right side & Left side) & 4 pcs screws	-

動画



© EtherWAN Systems, Inc. All rights reserved. 20250702

EtherWAN is constantly developing and improving products. Specifications are subject to change without notice and without incurring any obligation.