

## EX71900G シリーズ

広範囲動作温度対応産業用/マネジードギガビット8ポート+4ポート100/1G/2.5G SFPイーサネットスイッチ



### 概要

EX71900G シリーズは、次世代 2.5G 産業用ネットワークの常識を刷新する、圧倒的なテクノロジー革新を実現しました。

洗練されたファンレス設計とスマートマネジメントを融合し、産業ネットワークにこれまでにない性能向上をもたらします。

最大 8 ポートの Gigabit RJ45、そして 4 ポートの SFP アップリンクを搭載。光ファイバーポートは 100Mbps / 1Gbps / 2.5Gbps に柔軟対応し、既存環境から未来の高速通信ニーズまでダイナミックにカバー。急速に高まる帯域幅要求にも余裕を持って応えます。

スリムで省スペースな産業用デザインに、豊富な取り付けオプションを組み合わせることで、設置はこれまで以上にスマートでスムーズに。

狭い空間でも制約の多い現場でも、性能を妥協することなく、最適なネットワーク構築が可能です。

EX71900G シリーズは、厳しい環境やミッションクリティカルなアプリケーションのために生まれました。Layer 2 マネジメントに加え、Layer 3 の先進機能まで統合し、途切れない高品質接続を保証。

スマートシティ、交通インフラ、工場の自動化など、未来を支えるあらゆるフィールドで、強力なネットワーク基盤を実現します。

EtherWAN — "When Connectivity is Crucial."

## 特長

### + 2.5GbE 高帯域幅と拡張性

- 高帯域幅接続向けの8ポート10/100/1000BASE-T(X)
- ファイバーコネクション用の最大4つの100/1000/2500BASE SFPアップリンクポート
- 全二重通信で動作するフルキャパシティのスイッチング

### + 独創的なデザインと究極のパフォーマンス

- コンパクトと多様な取付
- コネクタ前面設計

### + 通気性のない厳しい環境向けの産業用仕様

- 広範囲な動作温度範囲 -40°Cから75°Cファンレス
- 高い耐衝撃性、熱ショック耐性、および電気ノイズ耐性
- 6KVサージ保護設計

### + L3 機能

- 静態路由、RIP v1/v2, 和 OSPF
- VRRP 虚擬路由器備援協定
- スタティックルート、RIP、VRRP、OSPF

## 機能

### + Interface

- CLI console, SSH, Web GUI

### + Management

- Firmware Upgrade
- Configuration Backup
- DHCP Server/Client/Snooping/Relay
- RMON (Remote Monitoring)
- Port Mirroring
- NTP (Network Time Protocol) Synchronization
- LLDP (Link Layer Discovery Protocol)
- IPv4/IPv6
- SNMP v1/v2c/v3
- RESTful API

### + Security

- MAC Address Filtering
- Enable/Disable Port
- Storm Control
- System logging
- Remote Authentication through RADIUS and TACACS+
- Complex Password Support
- Multi-User Login and Privileged Access Management
- SSH for CLI and Telnet Security
- SSL and HTTPS for Web Security
- ACL (Access Control List)

### + Layer 2 Features

#### Auto-Negotiation for Port Speed and Duplex

- Flow Control
- IEEE 802.3x full duplex mode
- Back-pressure half duplex mode

#### Redundant Protocols

- IEEE 802.1D STP
- IEEE 802.1w RSTP
- IEEE 802.1s MSTP
- ITU-T G.8032 Ethernet Ring Protection Switch (ERPS)

#### VLANs

- IEEE 802.1Q Tag VLANs
- GVRP
- GMRP

#### Link Aggregation

- Static Trunk (8 groups)
- IEEE 802.3ad LACP

#### IGMP Snooping v1/v2/v3

### + Layer 3 Features

#### IP Packet Routing

- Maximum 512 hosts
- Maximum 64 routes
- Static routing
- RIP v1/v2
- OSPF v2

#### Routing Redundancy

- VRRP v2

## + Quality of Service (QoS)

- Priority Queues: 8 Queues per Port
- Traffic Classification Based on IEEE 802.1p CoS (Cost of Service), DSCP (Differentiated Services Code Point), WRR (Weighted Round Robin), and Strict Mode
- Rate Limiting (Ingress/Egress)

## + Software Properties and Performance

### Switching Fabric

- 36Gbps

### Forwarding Rate

- 26.78Mpps

### Max VLANs

- 256 groups (4096 VID)

### Jumbo Frame Size

- 9KB

### MAC Table Size

- 16K

### Packet Buffer Memory

- 512KB (4M bits)

## 仕様

### + Interface

#### Ethernet

- 8 x 10/100/1000BASE-T(X)
- 4 x 100/1000/2500BASE SFP

#### Console

- 1 x RJ45

#### Config Backup

- 1 x USB (Type A Connector)

#### Alarm Contact

- Relay output, current capacity 0.6A/30VDC

#### LED Indicators

- Per Unit: Power 1 (Green), Power 2 (Green), Fault (Red)
- Per Port: Link/Activity (Green)

### + Physical

#### Casing Material

- Metal (Aluminum)

#### IP Rating

- IP30

#### Dimensions

- 45 x 135 x 145mm (W x D x H)

#### Weight

- 0.43kg (0.95 lbs)

#### Installation Type

- DIN-rail mounting
- Rack mounting (Optional)
- Panel mounting (Optional)

## + Technology

### Standards

- IEEE 802.3 10BASE-T
- IEEE 802.3u 100BASE-TX/100BASE-FX
- IEEE 802.3ab 1000BASE-T
- IEEE 802.3ad link aggregation control
- IEEE 802.3z 1000BASE-SX/1000BASE-LX
- IEEE 802.3x full duplex and flow control
- IEEE 802.1D STP
- IEEE 802.1p QoS
- IEEE 802.1Q Tag VLANs
- IEEE 802.1s MSTP
- IEEE 802.1w RSTP
- IEEE 802.1x Radius
- IEEE 802.1ab LLDP
- IEEE 802.3az Energy-Efficient Ethernet (EEE)

### Forward/Filtering Rate

- 14,880pps for 10Mbps
- 148,809pps for 100Mbps
- 1,488,095pps for 1000Mbps
- 3,720,238pps for 2500Mbps

### Processing Type

- Store-and-forward
- Auto-negotiation
- Half-duplex back-pressure and full-duplex flow control
- Auto MDI/MDIX

### System Memory

- 1GB DDR3 SDRAM

### Flash Storage

- 128MB

## + Regulatory

### ISO

- Manufactured in ISO-9001 facility

### EMI

- FCC Part 15B Class A
- VCCI Class A
- EN 61000-6-4
- EN 61000-3-2
- EN 61000-3-3
- EN 55032
- BSMI

### EMS

- EN 61000-6-2
- - IEC 61000-4-2 (ESD)
- - IEC 61000-4-3 (Radiated RFI)
- - IEC 61000-4-4 (Burst)
- - IEC 61000-4-5 (Surge)
- - IEC 61000-4-6 (Induced RFI)
- - IEC 61000-4-8 (Magnetic field)

### Safety

- UL 62368

### Railway

- EN 50121-4

### Vibration

- IEC 60068-2-6

### Shock

- IEC 60068-2-27

### Free Fall

- IEC 60068-2-31

## + Environmental

### Operating Temp.

- -40 to 75°C (-40 to 167°F)

### Storage Temp.

- -45 to 85°C (-49 to 185°F)

### Relative Humidity

- 5% to 95% (non-condensing)

### MTBF

- 3,330,902 hours

## + Power

### Input

- 12-48VDC Redundant (Terminal block)

### Power Consumption

- System only: 6.3W
- Full load: 13.2W

### Protection

- Reverse Polarity Protection

## + Warranty

### Length

- Limited Lifetime

### Details

- [www.etherwan.com/support/warranty-policy](http://www.etherwan.com/support/warranty-policy)

## + What's Included

### Device

- Ethernet switch

### Cables

- 1 Console cable

### Installation

- DIN-Rail mounting kit

# 応用例

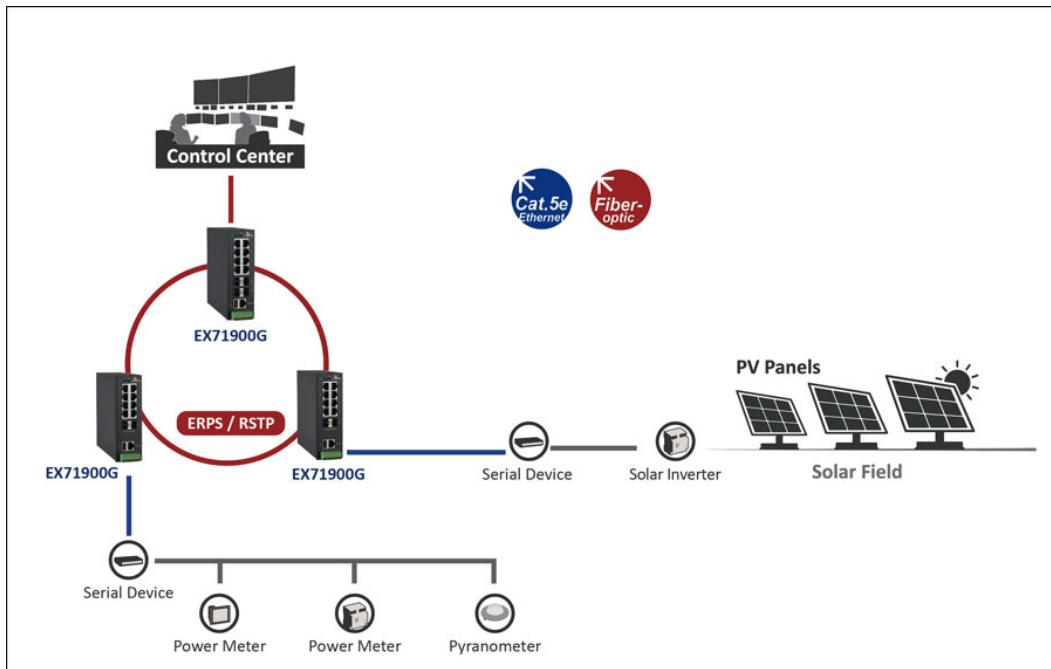

# 寸法図

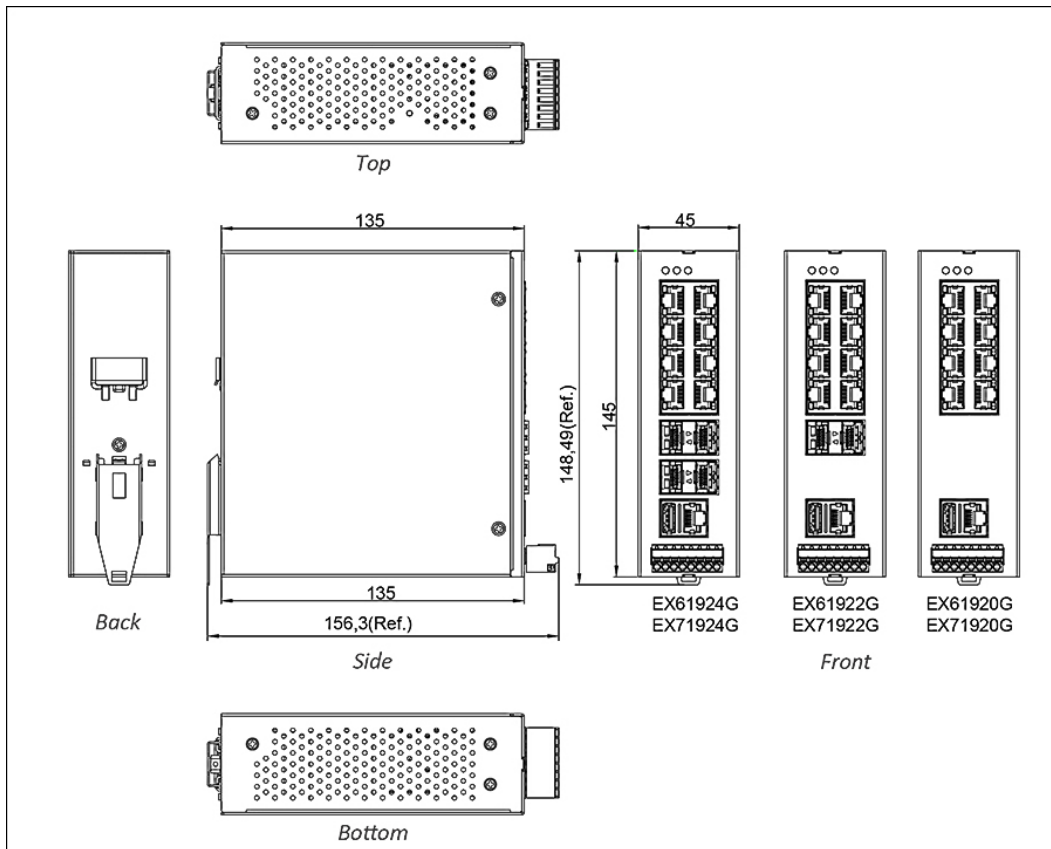

## 製品型番

### + Model

EX71924G-1NT	8-port 10/100/1000BASE-T(X) + 4-port 100/1000/2500BASE SFP
EX71922G-1NT	8-port 10/100/1000BASE-T(X) + 2-port 100/1000/2500BASE SFP
EX71920G-1NT	8-port 10/100/1000BASE-T(X)

### + Accessories

#### SFP Modules

Model Number	Transmission Speed	Mode	Distance	Operating Temperature	Wavelength	Connector Type	DDM
SFP2IS20M	2500Mbps	Single-mode	20km	-40 to 85°C	1310nm	Duplex LC	✓
SFP2IM2AM	2500Mbps	Multi-mode	160m	-40 to 85°C	850nm	Duplex LC	✓
SFP2XT1AM	2500Mbps	-	100m	-40 to 85°C	-	RJ-45	-
SFPGIM5AM	1000Mbps	Multi-mode	275/550m	-40 to 85°C	850nm	Duplex LC	✓
SFPGIM02M	1000Mbps	Multi-mode	2km	-40 to 85°C	1310nm	Duplex LC	✓
SFPGIS10M	1000Mbps	Single-mode	10km	-40 to 85°C	1310nm	Duplex LC	✓
SFPGIS20M	1000Mbps	Single-mode	20km	-40 to 85°C	1310nm	Duplex LC	✓
SFPGXT1AM	1000Mbps	-	100m	-40 to 85°C	-	RJ-45	-
EX-0155NSP-MB2L-A	100Mbps	Multi-mode	2km	-40 to 85°C	1310nm	Duplex LC	-
SFPMIS20M (DDM)	100Mbps	Single-mode	20km	-40 to 85°C	1310nm	Duplex LC	✓

For more SFP, please visit website: [www.etherwan.com/products/sfp-fiber-transceiver](http://www.etherwan.com/products/sfp-fiber-transceiver)

#### Industrial DIN-Rail Power Supplies

Model Number	Input Voltage	Output Voltage	Description	Operating Temperature
--------------	---------------	----------------	-------------	-----------------------

<b>HDR-30-12</b>	85 - 264VAC	12VDC	30W/ 2A DIN Rail 12VDC Industrial Power Supply	-30 to 70°C
<b>HDR-30-24</b>	85 - 264VAC	24VDC	30W/1.5A DIN-Rail 24VDC Industrial Power Supply	-30 to 70°C
<b>EDR-75-48</b>	90 - 264VAC	48VDC	75W/1.6A DIN-Rail 48VDC Industrial Power Supply	-20 to 70°C

For more Power Supplies, please visit website: [www.etherwan.com/products/din-rail-power-supply](http://www.etherwan.com/products/din-rail-power-supply).

## + Mounting Kits

Part Name	Description	Image
KP-BK78900G	Panel Mounting Bracket	
KR-BK71900G	Rack Mounting Bracket	